

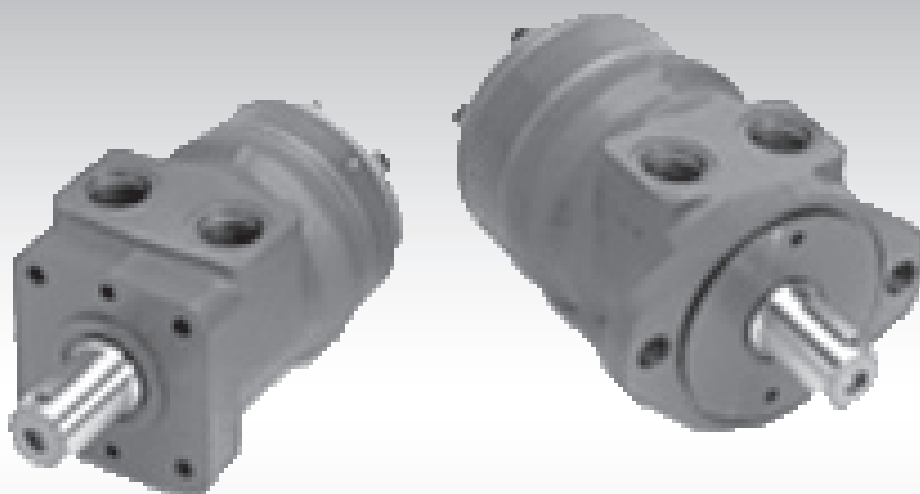

Technical Information

# Orbital Motors DH and DS





F 301 245

### A Wide Range of Orbital Motors

Danfoss Power Solutions is a world leader within production of low speed hydraulic motors with high torque. We can offer more than 3000 different hydraulic motors, categorised in types, variants and sizes (incl. different shaft versions).

The motors vary in size (rated displacement) from 8 cm<sup>3</sup> [0.50 in<sup>3</sup>] to 800 cm<sup>3</sup> [48.9 in<sup>3</sup>] per revolution.

Speeds range up to approx. 2500 min<sup>-1</sup> (rpm) for the smallest type and up to approx 600 min<sup>-1</sup> (rpm) for the largest type.

Maximum operating torques vary from 13 Nm [115 lbf-in] to 2700 Nm [24,000 lbf-in] (peak) and maximum outputs are from 2.0 kW [2.7 hp] to 70 kW [95 hp].

Characteristic features:

- Smooth running over the entire speed range
- Constant operating torque over a wide speed range
- High starting torque
- High return pressure without the use of drain line (High pressure shaft seal)
- High efficiency
- Long life under extreme operating conditions
- Robust and compact design
- High radial and axial bearing capacity
- For applications in both open and closed loop hydraulic systems
- Suitable for a wide variety of hydraulics fluids

**A Wide Range of Orbital Motors  
(continued)**

The programme is characterised by technical features appealing to a large number of applications and a part of the programme is characterised by motors that can be adapted to a given application. Adaptions comprise the following variants among others:

- Motors with corrosion resistant parts
- Wheel motors with recessed mounting flange
- OMP and OMR- motors with needle bearing
- OMR motor in low leakage version
- OMR motors in a super low leakage version
- Short motors without bearings
- Ultra short motors
- Motors with integrated positive holding brake
- Motors with integrated negative holding brake
- Motors with integrated flushing valve
- Motors with speed sensor
- Motors with tacho connection
- All motors are available with black finish paint

The Danfoss Orbital Motors are used in the following application areas:

- Construction equipment
- Agricultural equipment
- Material handling & Lifting equipment
- Forestry equipment
- Lawn and turf equipment
- Special purpose
- Machine tools and stationary equipment
- Marine equipment

**Survey of Literature with Technical Data on Danfoss Hydraulic Motors**

Detailed data on all Danfoss Orbital Motors can be found in our motor catalogue, which is divided into individual subcatalogues:

- General information on Danfoss Orbital Motors: function, use, selection of orbital motor, hydraulic systems, etc.
- Technical data on small motors: OML and OMM
- Technical data on medium sized motors: OMP, OMR, OMH
- Technical data on medium sized motors: DH and DS
- Technical data on medium sized motors: OMEW
- Technical data on medium sized motors: VMP
- Technical data on medium sized motors: VMR
- Technical data on large motors: OMS, OMT and OMV
- Technical data on large motors: TMT
- Technical data on large motors: TMV

A general survey brochure on Danfoss Orbital Motors gives a quick motor reference based on power, torque, speed and capabilities.

T301 123

**Contents**

<b>A Wide Range of Orbital Motors</b> .....	2
Survey of Literature with Technical Data on Danfoss Hydraulic Motors.....	3
<b>DH and DS Orbital Motor Data Survey</b> .....	5
Speed, Torque and Output.....	5
<b>DH</b> .....	6
Versions.....	6
Code Numbers.....	7
Technical Data.....	8
Technical Data for DH with 1 in Cylindrical and 1 in-6b Splined Shaft.....	8
Max. Permissible Shaft Seal Pressure.....	9
Pressure Drop in Motor.....	9
Oil Flow in Drain Line.....	10
Direction of Shaft Rotation.....	10
Permissible Shaft Loads for DH.....	11
Function Diagrams.....	12
Shaft Version.....	17
Port Thread Versions.....	18
Dimensions.....	19
Dimensions – US Version.....	19
<b>DS</b> .....	22
Versions.....	22
Code Numbers.....	23
Technical Data.....	24
Technical data for DS with 1 in cylindrical and 1 in-6b splined shaft.....	24
Max. Permissible Shaft Seal Pressure.....	25
Pressure Drop in Motor.....	25
Max. permissible shaft seal pressure.....	25
Oil Flow in Drain Line.....	26
Direction of Shaft Rotation.....	26
Permissible Shaft Loads for DS.....	27
Function Diagrams.....	28
Shaft Version.....	33
Port Thread Versions.....	34
Dimensions.....	35
Dimensions – US Version.....	35
<b>Hydraulic Systems</b> .....	38
Installation of the Danfoss Orbital Motors.....	38
Starting Up and Running in the Hydraulic System.....	38
Operation.....	38
Maintenance.....	38
<b>Weight of Motors</b> .....	39

**Speed, Torque and Output**

The bar diagrams, see page 5, are useful for a quick selection of relevant motor size for the application. The final motor size can be determined by using the function diagram for each motor size.

- DH can be found on pages 12-16
- DS can be found on pages 28-32

The function diagrams are based on actual tests on a representative number of motors from our production. The diagrams apply to a return pressure between 5 and 10 bar [75 and 150 psi] when using mineral based hydraulic oil with a viscosity of 35 mm<sup>2</sup>/s [165 SUS] and a temperature of 50°C [120°F]. For further explanation concerning how to read and use the function diagrams, please consult the paragraph "Selection of motor size" in the technical information "General" 520L0232.

DH and DS Orbital Motor Data Survey

Speed, Torque and Output

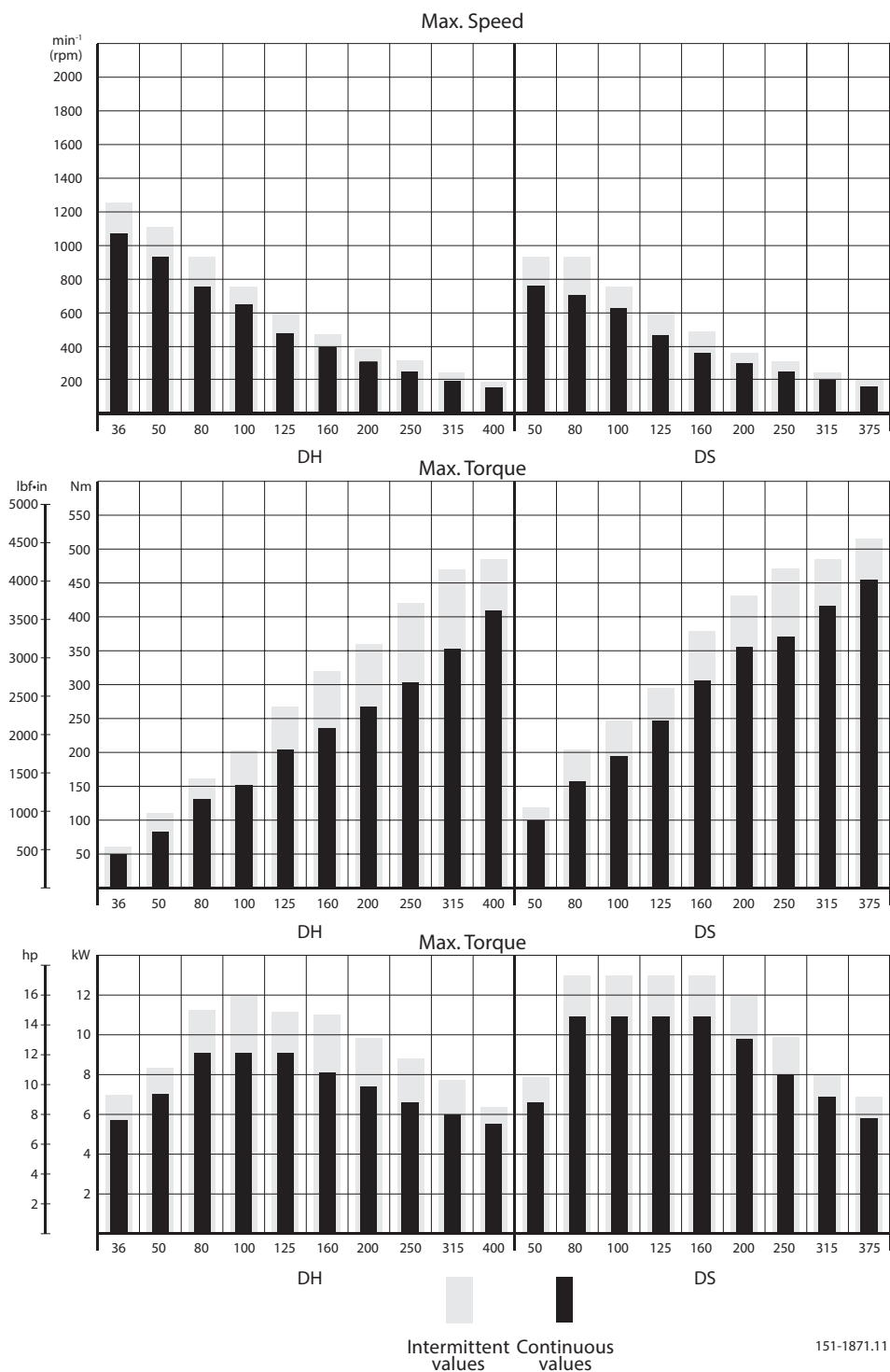

151-1871.11

**DS**
**Versions**

Mounting flange	Shaft	Port size	European version	US version	Side port version	End port version	Flange port version	Standard shaft seal	High pressure shaft seal	Drain connection	Check valve	Specials	Main type designation
2 hole oval flange (A2-flange)	Cyl. 1 in	7/8 - 14 UNF		○	○				○	No	No		DS
		7/8 - 14 UNF		○	○				○	Yes	No		DS
		1/2 - 14 NPTF		○	○				○	No	No		DS
	1 in - 6B spl.	7/8 - 14 UNF		○	○				○	No	No		DS
Square flange (C-flange)	Cyl. 1 in	7/8 - 14 UNF		○	○				○	No	No		DS
		1/2 - 14 NPTF		○	○				○	No	No		DS

Function diagram - see page : →

*Features available (options) :*

 Reverse rotation  
 Drain port  
 Painted

**Code Numbers**

CODE NUMBERS	DISPLACEMENT [cm <sup>3</sup> ]									Technical data - Page	Dimensions - Page
	50	80	100	125	160	200	250	315	375		
151-	2301	2302	2303	2304	2305	2306	2307	2308	-	24	35
151-	-	3702	3703	3704	-	3706	3707	3708	-	24	36
151-	-	2382	2383	-	2385	2386	2387	-	2389	24	35
151-	-	2312	2313	2314	-	2316	-	2318	2319	24	35
151-	2341	2342	2343	2344	2345	2346	2347	2348	2349	24	37
151-	2421	-	2423	-	2425	2426	2427	-	2429	24	37
→	28	28	29	29	30	30	31	31	32		

**Ordering**

Add the four character prefix "151-" to the four digit numbers from the chart for complete code number.

**Example:**

151-2305 for an DS 160 with A2-flange, cyl. 1 in shaft, port size 7/8 - 14 UNF and without drain connection.

---

Orders will not be accepted without the four character prefix.

---

**Technical Information      Orbital Motors, DS**
**Technical Data**
*Technical data for DS with 1 in cylindrical and 1 in-6b splined shaft*

Type Motor size			DS	DS	DS	DS	DS	DS	DS	DS	
			50	80	100	125	160	200	250	315	375
Geometric displacement	cm <sup>3</sup> [in <sup>3</sup> ]		51.6 [3.16]	80.3 [4.91]	99.8 [6.11]	124.1 [7.60]	155.4 [9.51]	198.2 [12.13]	248.1 [15.18]	310.1 [18.98]	390.7 [23.91]
Max. speed	min <sup>-1</sup> [rpm]	cont.	770	755	605	480	380	305	245	190	155
		int. <sup>2)</sup>	955	945	760	600	475	380	305	240	195
Max. torque <sup>1)</sup>	Nm [lbf-in]	cont.	93 [820]	159 [1405]	193 [1710]	247 [2190]	314 [2780]	350 [3100]	370 [3270]	415 [3670]	455 [4030]
		int. <sup>2)</sup>	116 [1025]	206 [1820]	237 [2100]	304 [2690]	378 [3350]	429 [3800]	469 [4150]	485 [4290]	515 [4560]
Max. output	kW [hp]	cont.	6.6 [8.9]	10.7 [14.3]	10.7 [14.3]	10.7 [14.3]	10.7 [14.3]	9.6 [12.9]	8.0 [10.7]	6.9 [9.3]	5.8 [7.8]
		int. <sup>2)</sup>	7.8 [10.5]	13.0 [17.4]	13.0 [17.4]	13.0 [17.4]	12.6 [16.9]	11.8 [15.8]	9.9 [13.3]	8.0 [10.7]	6.9 [9.3]
Max. pressure drop	bar [psi]	cont.	138 [2000]	138 [2000]	138 [2000]	138 [2000]	138 [2000]	124 [1800]	107 [1550]	97 [1400]	83 [1200]
		int. <sup>2)</sup>	172 [2500]	172 [2500]	172 [2500]	172 [2500]	172 [2500]	155 [2250]	138 [2000]	114 [1650]	97 [1400]
Max. oil flow	l/min [US gal/ min]	cont.	40 [10.6]	60 [15.9]	60 [15.9]	60 [15.9]	60 [15.9]	60 [15.9]	60 [15.9]	60 [15.9]	60 [15.9]
		int. <sup>2)</sup>	50 [13.2]	75 [19.8]	75 [19.8]	75 [19.8]	75 [19.8]	75 [19.8]	75 [19.8]	75 [19.8]	75 [19.8]
Max. starting pressure with unloaded shaft	bar [psi]		10 [145]	10 [145]	10 [145]	10 [145]	10 [145]	10 [145]	7 [100]	7 [100]	7 [100]
Min. starting torque	at max. press. drop cont. Nm [lbf-in]		76 [670]	118 [1045]	164 [1455]	204 [1810]	256 [2265]	294 [2600]	318 [2815]	358 [3170]	387 [3425]
	at max. press. drop int. <sup>2)</sup> Nm [lbf-in]		95 [840]	148 [1305]	205 [1820]	255 [2260]	320 [2830]	367 [3250]	408 [3615]	423 [3745]	453 [4010]

Type		Max. inlet pressure	Max return pressure with drain line
DS 50 - 375	bar [psi]      cont.	138 [2000]	138 [2000]
	bar [psi]      int. <sup>1)</sup>	172 [2500]	172 [2500]

1) 6B splined shaft is recommended for operating torque of 280 Nm [2500 lbf-in] or more.

2) Intermittent operation: the permissible values may occur for max. 10% of every minute.



Technical Data

**Max. Permissible Shaft Seal Pressure**

*DS with HPS and without drain connection:*  
The shaft seal pressure equals the average of input pressure and return pressure.

$$P_{\text{seal}} = \frac{P_{\text{in}} + P_{\text{return}}}{2}$$

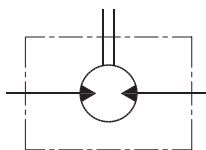

151-1743.10

*DS with HPS and drain connection:*  
The shaft seal pressure equals the pressure in the drain line.

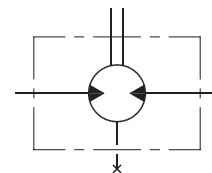

151-1855.10

*Max. permissible shaft seal pressure*

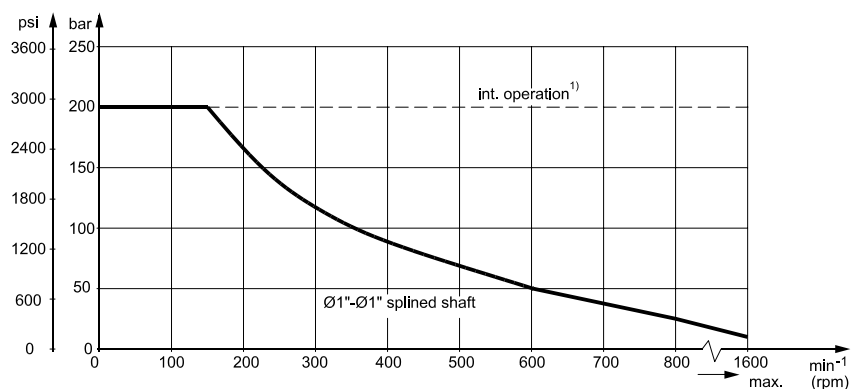

151-1872.10

**Pressure Drop in Motor**

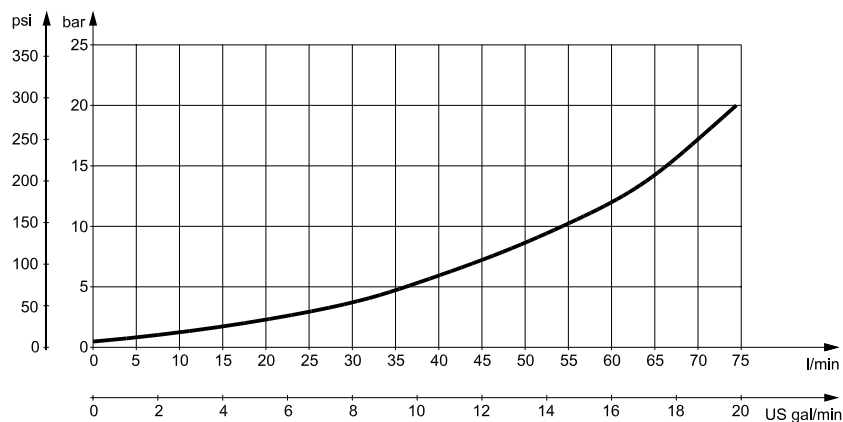

151-1913.10

The curve applies to an unloaded motor shaft and an oil viscosity of 35 mm<sup>2</sup>/s [165 SUS]

**Technical Data**
**Oil Flow in Drain Line**

The table shows the max. oil flow in the drain line at a return pressure less than 5-10 bar [75-150 psi].

Pressure drop bar [psi]	Viscosity mm <sup>2</sup> /s [SUS]	Oil flow in drain line l/min [US gal/min]
100 [1450]	20 [100]	2.5 [0.66]
	35 [165]	1.8 [0.78]
140 [2030]	20 [165]	3.5 [0.93]
	35 [165]	2.8 [0.74]

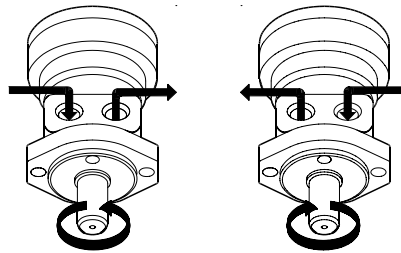
**Direction of Shaft Rotation**

151-1874.10

**Technical Data**
**Permissible Shaft Loads for DS**

 The permissible radial shaft load ( $P_R$ ) depends on

- speed (n)
- distance (l) from the point of load to the mounting flange
- mounting flange version
- shaft version

Mounting flange	Square flange 2-hole oval flange (US version)
Shaft version	1 in cylindrical shaft 1 in-6B splined shaft
Permissible shaft load ( $P_R$ ) l in mm	$\frac{650}{n} \times \frac{228000}{87 + l} \text{ N}^*$
Permissible shaft load ( $P_R$ ) l in inch	$\frac{1460}{n} \times \frac{898}{3.425 + l} \text{ lbf}^*$

\*  $n \geq 200 \text{ min}^{-1} \text{ (rpm)}$ ;  $l \leq 55 \text{ mm [2.2 in]}$   
 $n < 200 \text{ min}^{-1} \text{ (rpm)}$ ;  $\Rightarrow P_{R\text{max}} = 6500 \text{ N [1460 lbf]}$ , when using above formulas n has to be  $200 \text{ min}^{-1} \text{ (rpm)}$ .

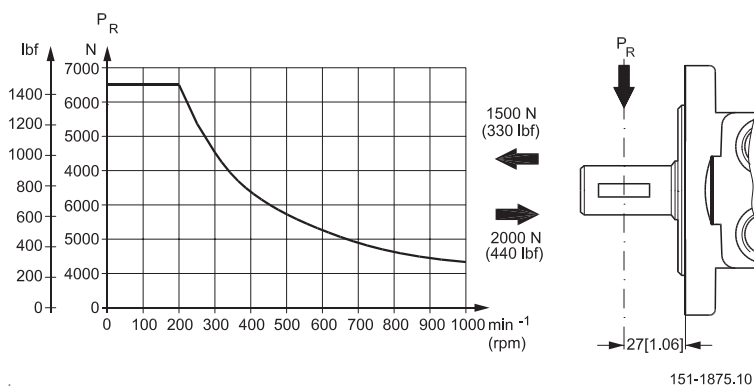
 The curve shows the relation between  $P_R$  and n

- when  $l = 27 \text{ mm [1.06 in]}$  for motors with oval and square mounting flange

Technical Data

Function Diagrams

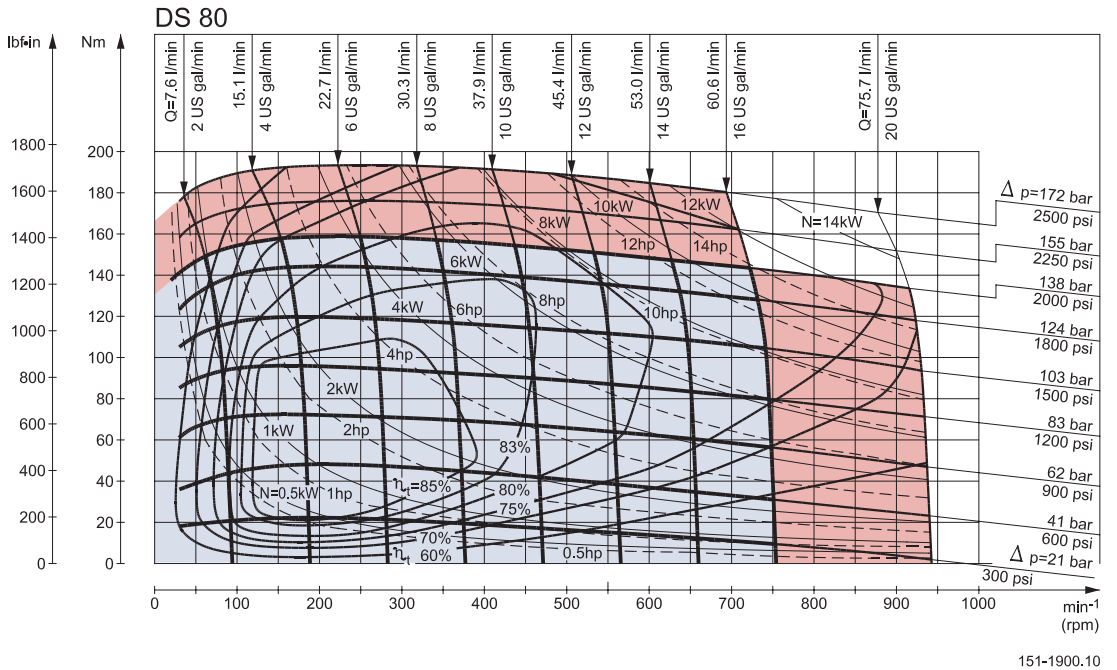
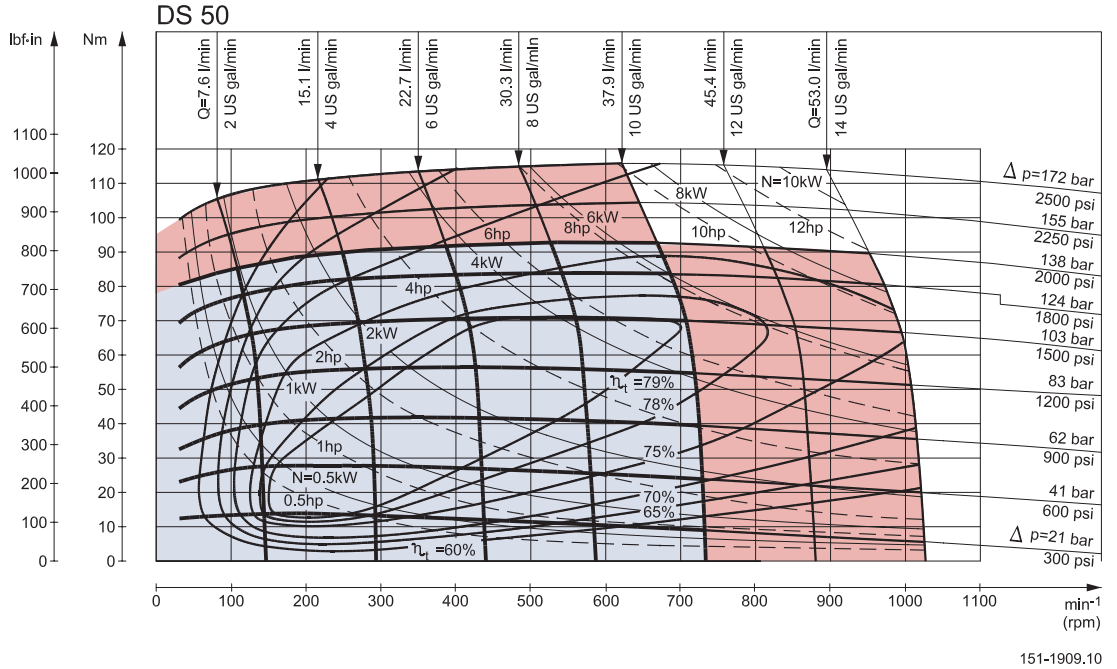

Explanation of function diagram use, basis and conditions can be found on page 4.

- A: Continuous range
- B: Intermittent range (max. 10% operation every minute)

Max. permissible continuous/intermittent pressure drop for the actual shaft version can be found on page 24.

Intermittent pressure drop and oil flow must not occur simultaneously.

Technical Data

Function Diagrams

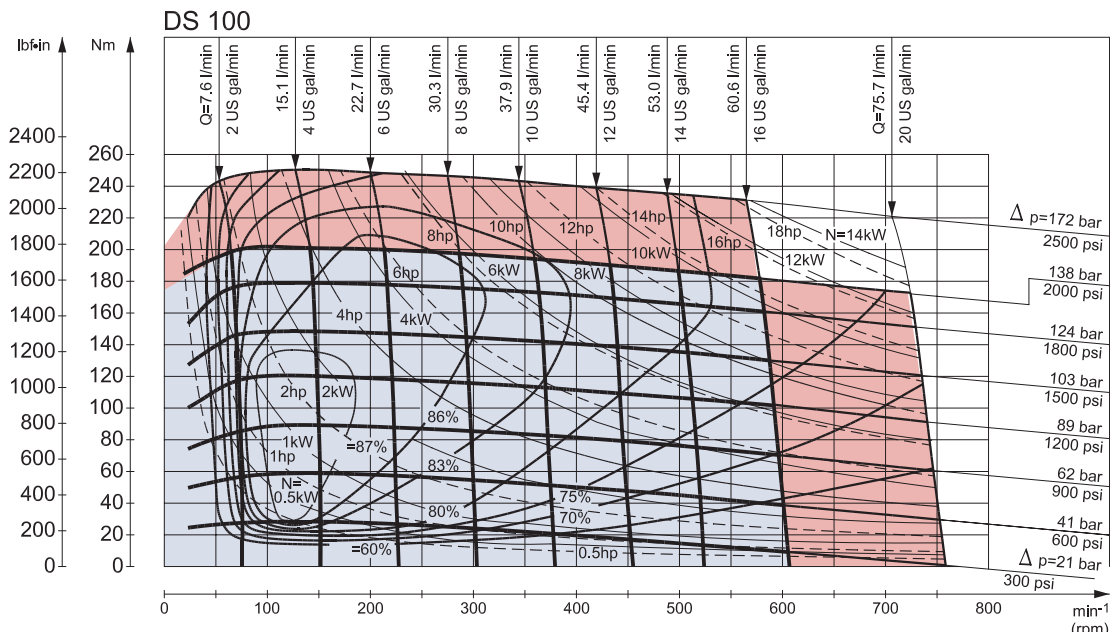

151-1889.10

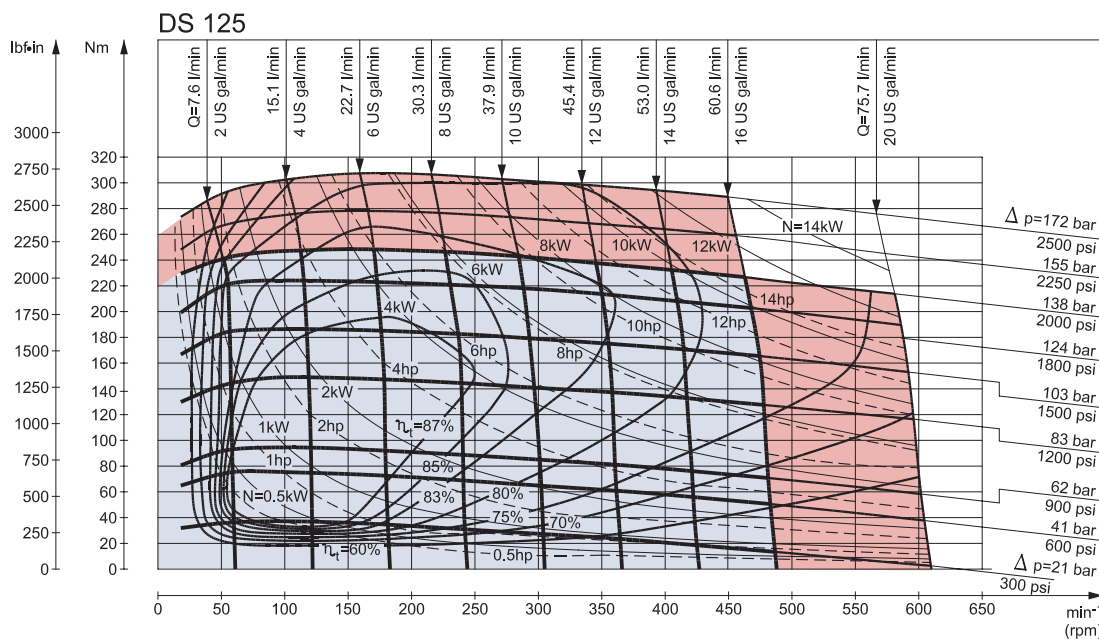

151-1886.10

Explanation of function diagram use, basis and conditions can be found on page 4.

- A: Continuous range
- B: Intermittent range (max. 10% operation every minute)

Max. permissible continuous/intermittent pressure drop for the actual shaft version can be found on page 24.

Intermittent pressure drop and oil flow must not occur simultaneously.

Technical Data

Function Diagrams

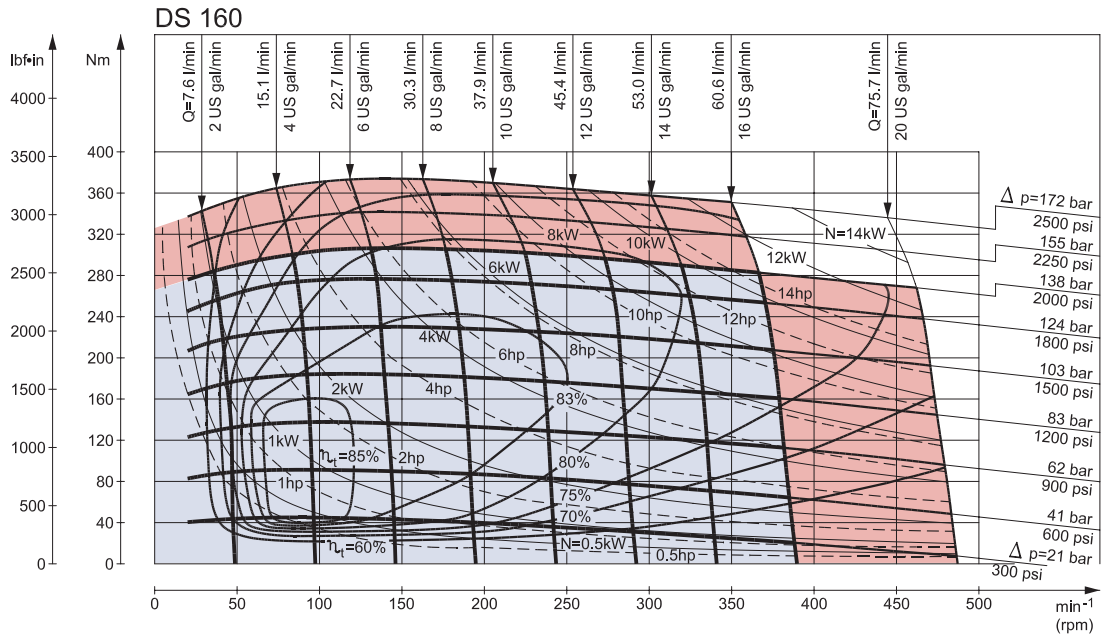

151-1883.10

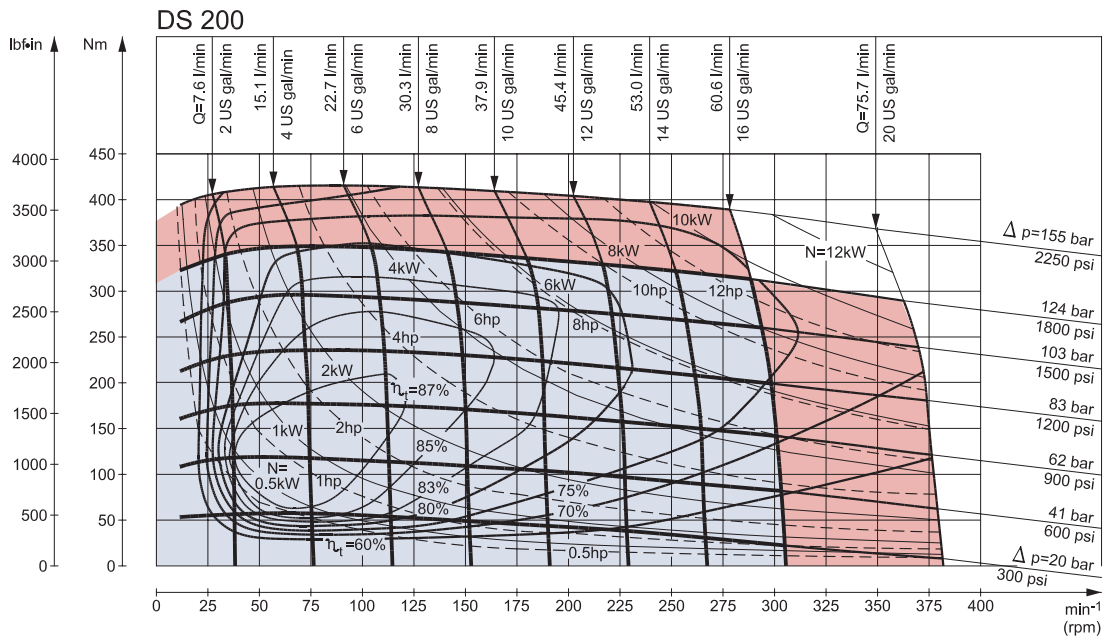

151-1887.10

Explanation of function diagram use, basis and conditions can be found on page 4.

- A: Continuous range
- B: Intermittent range (max. 10% operation every minute)

Max. permissible continuous/intermittent pressure drop for the actual shaft version can be found on page 24.

Intermittent pressure drop and oil flow must not occur simultaneously.

Technical Data

Function Diagrams

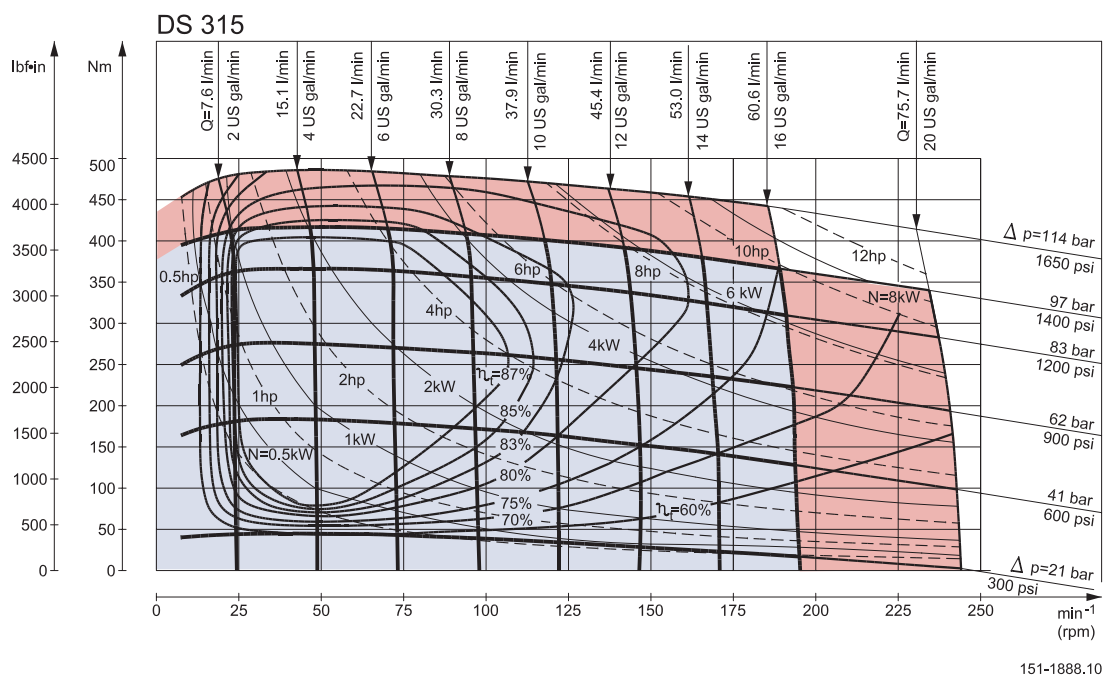
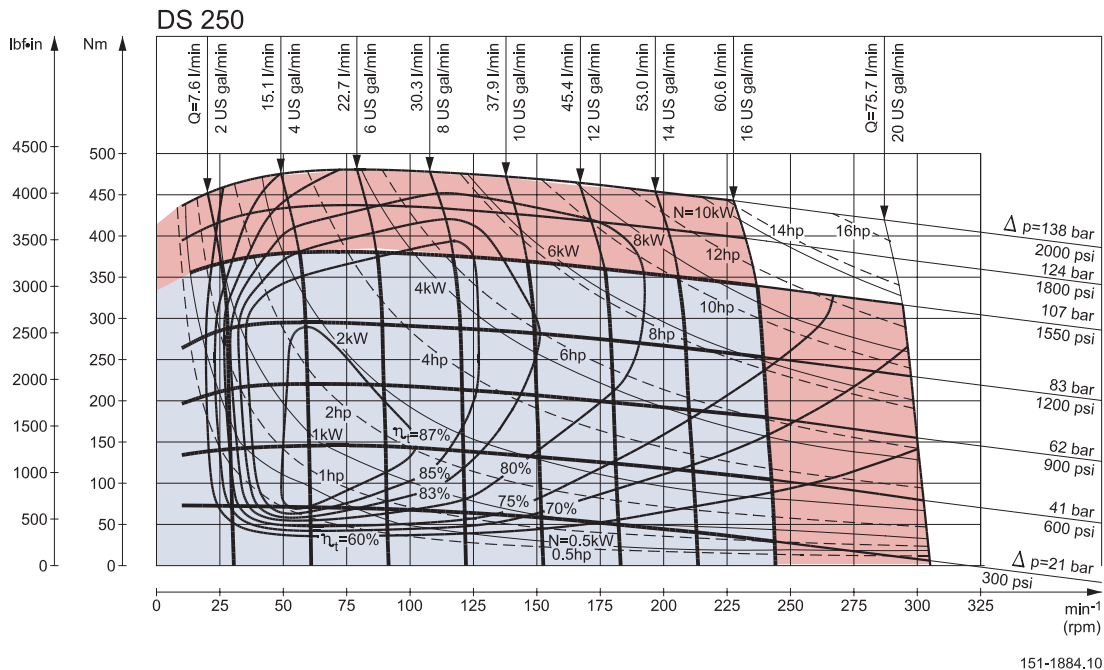

Explanation of function diagram use, basis and conditions can be found on page 4.

- A: Continuous range
- B: Intermittent range (max. 10% operation every minute)

Max. permissible continuous/intermittent pressure drop for the actual shaft version can be found on page 24.

Intermittent pressure drop and oil flow must not occur simultaneously.

Technical Data

Function Diagrams

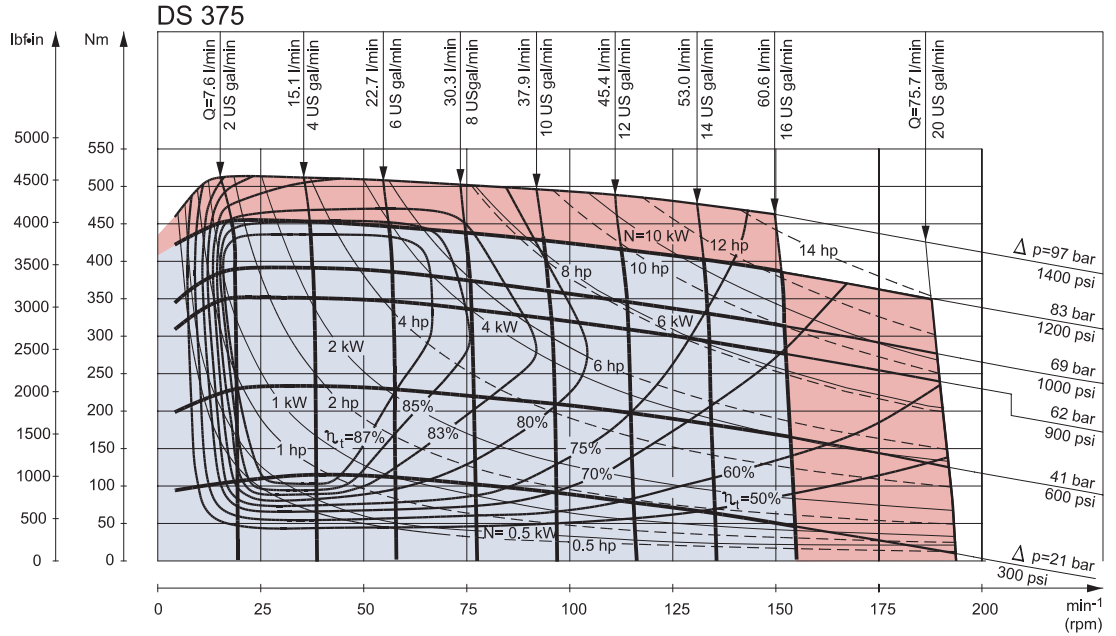

151-1882.10

Explanation of function diagram use, basis and conditions can be found on page 4.

- A: Continuous range
- B: Intermittent range (max. 10% operation every minute)

Max. permissible continuous/intermittent pressure drop for the actual shaft version can be found on page 24.

Intermittent pressure drop and oil flow must not occur simultaneously.



Technical Data

Shaft Version

US version

- A: Cylindrical shaft  
1 in
- C: Woodruff key  
1/4 x 1 in  
SAE J502

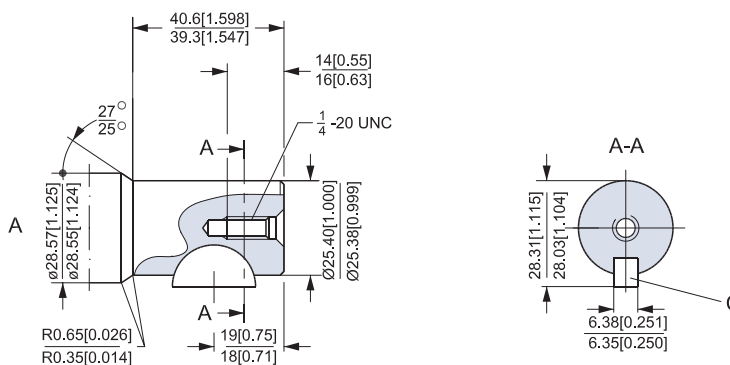

US version

- B: Splined shaft  
1 in - SAE 6B
- \* Deviates from B.S. 2059  
(SAE 6B)

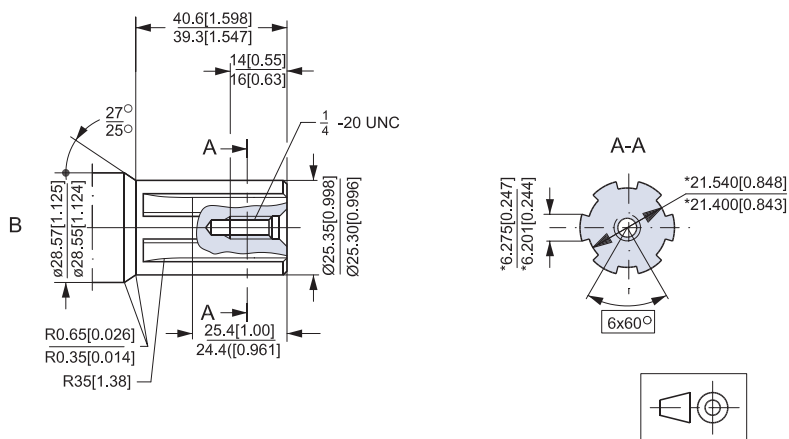

151-1876.10

6B splined shaft is recommended for operating torque of 280 Nm [2500 lbf-in] or more.

Technical Data

Port Thread Versions

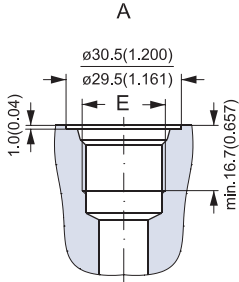

A: UNF main ports  
E: 7/8 - 14 UNF  
O-ring boss port

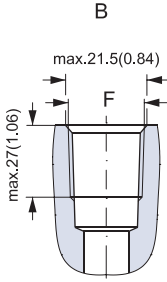

B: NPTF main ports  
F: 1/2 - 14 NPTF

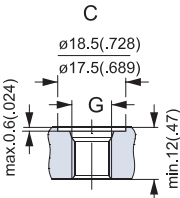

C: UNF drain port  
G: 7/16 - 20 UNF  
O-ring boss port

**Dimensions**
*Dimensions – US Version*

 Side port version with 2 hole oval mounting flange (A2-flange).  
 Port thread version.

Type	L mm [in]	L mm [in]
DS 50	125.6 [4.94]	9.0 [0.35]
DS 80	130.6 [5.14]	14.0 [0.55]
DS 100	130.6 [5.14]	14.0 [0.55]
DS 125	134.0 [5.28]	17.4 [0.69]
DS 160	138.4 [5.45]	21.8 [0.86]
DS 200	144.4 [5.69]	27.8 [1.09]
DS 250	151.4 [5.96]	34.8 [1.37]
DS 315	160.1 [6.30]	43.5 [1.71]
DS 375	171.4 [6.75]	54.8 [2.16]

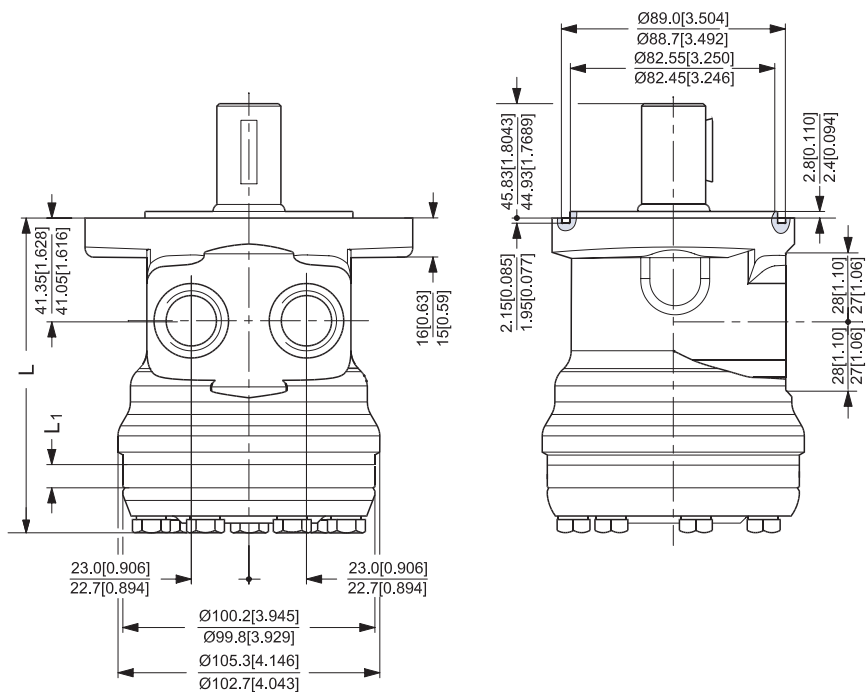

D: 7/8 - 14 UNF,  
 16.7 mm [0.66 in] deep  
 O-ring boss port or  
 1/2 - 14 NPTF

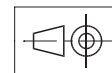
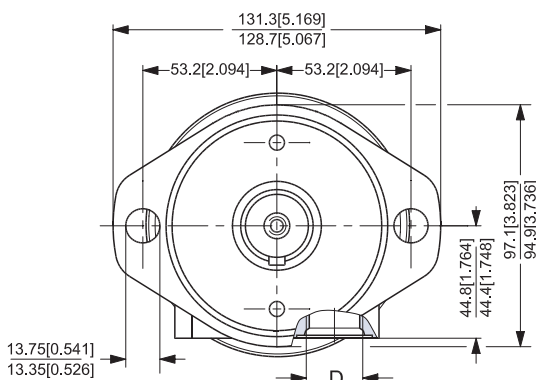

151-1898.10



**Dimensions**
*Dimensions – US Version*

 Side port version with square mounting flange (C-flange).  
 Port thread version.

Type	L mm [in]	L mm [in]
DS 50	125.6 [4.94]	9.0 [0.35]
DS 80	130.6 [5.14]	14.0 [0.55]
DS 100	130.6 [5.14]	14.0 [0.55]
DS 125	134.0 [5.28]	17.4 [0.69]
DS 160	138.4 [5.45]	21.8 [0.86]
DS 200	144.4 [5.69]	27.8 [1.09]
DS 250	151.4 [5.96]	34.8 [1.37]
DS 315	160.1 [6.30]	43.5 [1.71]
DS 375	171.4 [6.75]	54.8 [2.16]

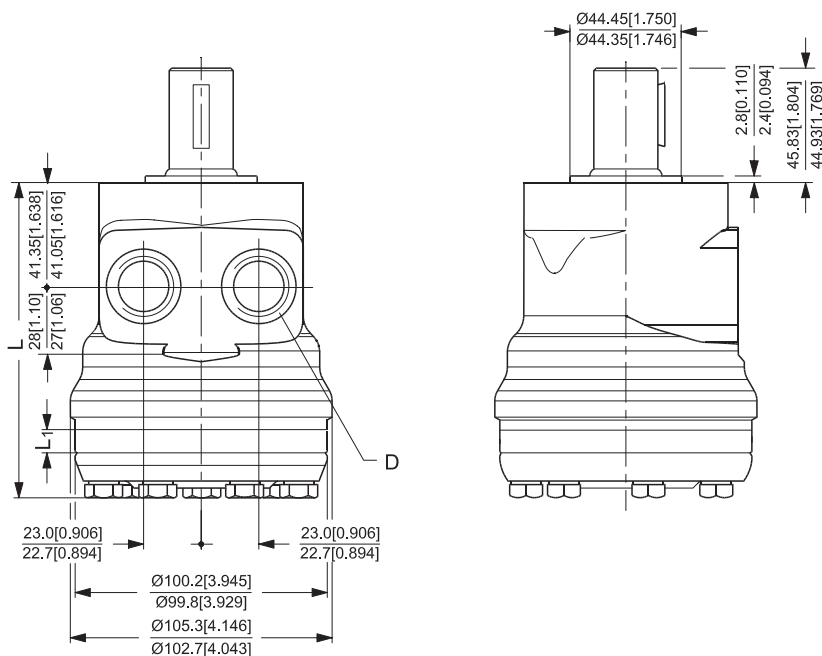

D: 7/8 - 14 UNF;  
 16.7 mm [0.66 in] deep  
 or 1/2 - 14 NPTF

E: 3/8 - 16 UNC;  
 15 mm [0.59 in] deep  
 (4-off)

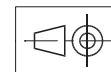
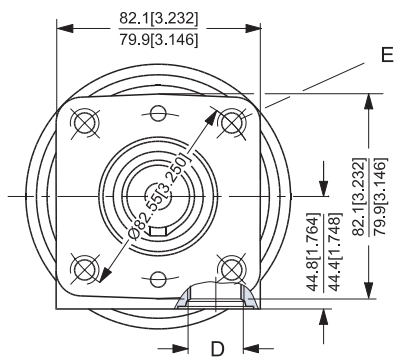

151-1897.10

**Hydraulic Systems****Installation of the Danfoss  
Orbital Motors***About the design*

- To ensure efficient operation all hydraulic components must be installed according to their individual instructions.
- The pump line must include a gage connection.
- To ensure designed contact and minimize the stress all mounting flanges must be flat.
- Hydraulic lines must be fitted correctly to prevent air entrapment.

*About the assembly*

- Follow the mounting instructions printed on the inside of the cardboard box.
- To prevent contamination, do not remove the plastic plugs from the connection ports until the fittings are ready to be assembled.
- Check that there is full face contact between the motor mounting flange and the mating part.
- Do not force the motor into place when tightening the mounting screws.
- Avoid unsuitable sealing material on fittings such as pack twine, Teflon and others.
- Use only bonded seals, O-rings, steel washers and the like.
- When tightening the fittings never use a torque higher than the max. tightening torque stated in the instructions.
- Make sure that the cleanliness of the oil used is better than 20/16 (ISO 4406). Always use a filter for oil refilling.

**Starting Up and Running in  
the Hydraulic System**

- Through a small-meshed filter fill up the tank with oil to the upper oil level mark .
- Start the drive engine, and if possible, let it work at its lowest speed. If the motor is provided with bleed screws, keep these open until the emerging oil is non-foaming.
- Check that all components are correctly connected (pump following the right direction of rotation etc.).
- In load-sensing systems, also make sure that the signal lines are free of entrapped air.
- Indications of air in the hydraulic system:
  - foam in the tank
  - jerky movements of motor and cylinder
  - noise
- If required, refill with oil.
- Connect the system to a separate tank that includes a filter (fineness max. 10 µm) with twice the capacity of the max. oil flow. Let the entire system run without load (no pressure) for about 30 minutes.
- Do not load the system until it is all bled and clean.
- Check the tightness of the system and make sure that its performance is satisfactory.
- Change the oil filter, and if required, refill with oil.

**Operation**

- Do not expose the motor to pressures, pressure drops and speeds above the max. values stated in the catalogue.
- Filter the oil to ensure that the contamination level 20/16 (ISO 4406) or better.

**Maintenance**

- When working with hydraulic systems, the main criteria of operating safety and endurance is careful maintenance
- Always renew and replace oil, oil filters and air filters according to the instructions given by the respective manufacturers
- Regularly check the condition of the oil
- Frequently check system tightness and oil level

**Weight of Motors**

Code no	Weight	
	kg	[lb]
151-2000	5.1	11.2
151-2001	5.1	11.2
151-2002	5.2	11.5
151-2003	5.4	11.9
151-2004	5.5	12.1
151-2005	5.7	12.6
151-2006	5.9	13.0
151-2007	6.1	13.4
151-2008	6.4	14.1
151-2009	6.9	15.2
151-2010	5.1	11.2
151-2011	5.1	11.2
151-2012	5.2	11.5
151-2013	5.4	11.9
151-2015	5.7	12.6
151-2016	5.9	13.0
151-2017	6.1	13.4
151-2018	6.4	14.1
151-2019	6.9	15.2
151-2040	4.8	10.6
151-2041	4.8	10.6
151-2042	4.9	10.8
151-2043	5.1	11.2
151-2044	5.2	11.5
151-2045	5.4	11.9
151-2046	5.6	12.3
151-2047	5.8	12.8
151-2048	6.1	13.4
151-2049	6.6	14.6
151-2080	5.1	11.2
151-2081	5.1	11.2
151-2082	5.2	11.5
151-2083	5.4	11.9

Code no	Weight	
	kg	[lb]
151-2085	5.7	12.6
151-2086	5.9	13.0
151-2087	6.1	13.4
151-2088	6.4	14.1
151-2089	6.9	15.2
151-2120	4.8	10.6
151-2121	4.8	10.6
151-2122	4.9	10.8
151-2123	5.1	11.2
151-2124	5.2	11.5
151-2125	5.4	11.9
151-2126	5.6	12.3
151-2127	5.8	12.8
151-2128	6.1	13.4
151-2129	6.6	14.6
151-2301	5.9	13.0
151-2302	6.1	13.4
151-2303	6.1	13.4
151-2304	6.2	13.7
151-2305	6.4	14.1
151-2306	6.7	14.8
151-2307	7.2	15.9
151-2308	7.7	17.0
151-2309	8.2	18.1
151-2312	6.1	13.4
151-2313	6.1	13.4
151-2314	6.2	13.7
151-2316	6.7	14.8
151-2318	7.7	11.2
151-2319	8.2	11.7
151-2341	5.6	12.3
151-2342	5.8	12.8
151-2343	5.8	12.8

Code no	Weight	
	kg	[lb]
151-2344	5.9	13.0
151-2345	6.1	13.4
151-2346	6.4	14.1
151-2347	6.9	15.2
151-2348	7.4	16.3
151-2349	7.9	17.4
151-2382	6.1	13.4
151-2383	6.1	13.4
151-2385	6.4	14.1
151-2386	6.7	14.8
151-2387	7.2	15.9
151-2389	8.2	18.1
151-2421	5.6	12.3
151-2423	5.8	12.8
151-2425	6.1	13.4
151-2426	6.4	14.1
151-2427	6.9	15.2
151-2429	7.9	17.4
151-3401	5.1	11.2
151-3402	5.2	11.5
151-3403	5.4	11.9
151-3407	6.1	13.4
151-3408	6.4	14.1
151-3409	6.9	15.2
151-3702	6.1	13.4
151-3703	6.1	13.4
151-3704	6.2	13.7
151-3706	6.7	14.8
151-3707	7.2	15.9
151-3708	7.7	17.0



**Products we offer:**

- Bent Axis Motors
- Closed Circuit Axial Piston Pumps and Motors
- Displays
- Electrohydraulic Power Steering
- Electrohydraulics
- Hydraulic Power Steering
- Integrated Systems
- Joysticks and Control Handles
- Microcontrollers and Software
- Open Circuit Axial Piston Pumps
- Orbital Motors
- PLUS+1® GUIDE
- Proportional Valves
- Sensors
- Steering
- Transit Mixer Drives

**Danfoss Power Solutions** is a global manufacturer and supplier of high-quality hydraulic and electronic components. We specialize in providing state-of-the-art technology and solutions that excel in the harsh operating conditions of the mobile off-highway market. Building on our extensive applications expertise, we work closely with our customers to ensure exceptional performance for a broad range of off-highway vehicles.

We help OEMs around the world speed up system development, reduce costs and bring vehicles to market faster.

Danfoss – Your Strongest Partner in Mobile Hydraulics.

**Go to [www.powersolutions.danfoss.com](http://www.powersolutions.danfoss.com) for further product information.**

Wherever off-highway vehicles are at work, so is Danfoss.

We offer expert worldwide support for our customers, ensuring the best possible solutions for outstanding performance. And with an extensive network of Global Service Partners, we also provide comprehensive global service for all of our components.

Please contact the Danfoss Power Solution representative nearest you.

**Comatrol**

[www.comatrol.com](http://www.comatrol.com)

**Schwarzmueller-Inverter**

[www.schwarzmueller-inverter.com](http://www.schwarzmueller-inverter.com)

**Turolla**

[www.turollaocg.com](http://www.turollaocg.com)

**Valmova**

[www.valmova.com](http://www.valmova.com)

**Hydro-Gear**

[www.hydro-gear.com](http://www.hydro-gear.com)

**Daikin-Sauer-Danfoss**

[www.daikin-sauer-danfoss.com](http://www.daikin-sauer-danfoss.com)

Local address:

**Danfoss Power Solutions (US) Company**  
2800 East 13th Street  
Ames, IA 50010, USA  
Phone: +1 515 239 6000

**Danfoss Power Solutions GmbH & Co. OHG**  
Krokamp 35  
D-24539 Neumünster, Germany  
Phone: +49 4321 871 0

**Danfoss Power Solutions ApS**  
Nordborgvej 81  
DK-6430 Nordborg, Denmark  
Phone: +45 7488 2222

**Danfoss Power Solutions Trading (Shanghai) Co., Ltd.**  
Building #22, No. 1000 Jin Hai Rd  
Jin Qiao, Pudong New District  
Shanghai, China 201206  
Phone: +86 21 3418 5200

Danfoss can accept no responsibility for possible errors in catalogues, brochures and other printed material. Danfoss reserves the right to alter its products without notice. This also applies to products already on order provided that such alterations can be made without changes being necessary in specifications already agreed. All trademarks in this material are property of the respective companies. Danfoss and the Danfoss logotype are trademarks of Danfoss A/S. All rights reserved.